

- 6" FPT PHOENIX CURVED SECONDARY EMERGENCY VENT
- 2" FPT PHOENIX FLAT STICK/GAUGE/STAGE 1 VAPOR RECOVERY
- 2" FPT PHOENIX FLAT STICK/GAUGE/STAGE 1 VAPOR RECOVERY
- 4" FPT PHOENIX CURVED FILL
- 6" FPT PHOENIX CURVED PRIMARY EMERGENCY VENT
- 2" FPT PHOENIX FLAT NORMAL VENT
- 2" FPT PHOENIX FLAT SPARE/STAGE 2 VAPOR RECOVERY
- 4" FPT PHOENIX CURVED PUMP/DISPENSER

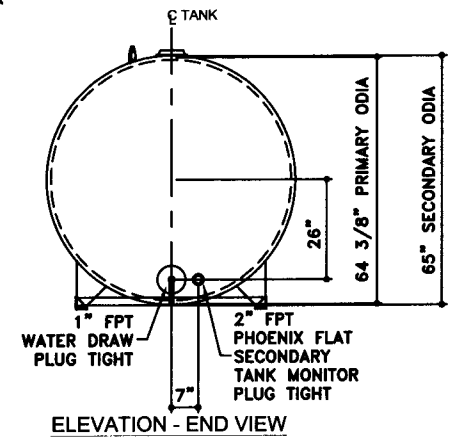
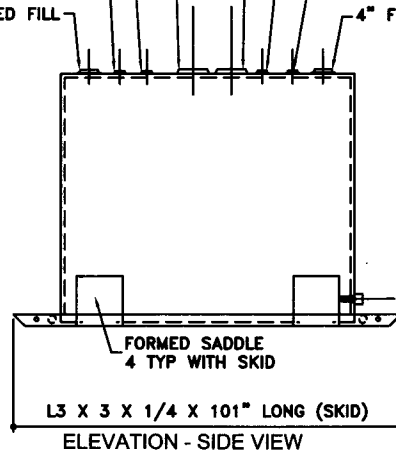
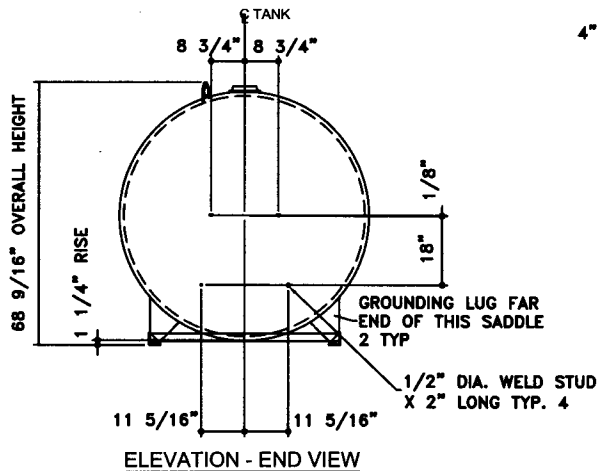

TOLERANCES	
TANK	
CAPACITY	-0% / +10
OVERALL LENGTH	-0" / +2"
OVERALL WIDTH	-0" / +1"
OVERALL HEIGHT	-1/2" / +1/2"
OTHER DIMENSIONS	-1/4" / +1/4"

UL 142 (BUILT & LABELED)
 HOLDDOWNS ARE SEISMIC RATED
 DOUBLE WALL TANK
 SKID TANK

STEEL: ASTM A36
 PRIMARY TANK
 SHELL: 10 GAUGE (9/64")
 HEAD: 10 GAUGE (9/64")

COATING:
 "R" EXTERIOR COATING, ACE 1A
 RED SHOP COAT 1-3 MILS
 "A" EXTERIOR ACE 3A COATING:
 SP-6 GRIT BLAST
 3A COLOR: #WH01 (WHITE)
 1 CT TN-161 EPOXY 3.0-5.0 MILS
 1 CT TN-74 URETHANE 2.0-3.0 MILS
 TDFT 5.0-8.0 MILS

SPECIAL INSTRUCTIONS
 PLUG TIGHT
 WRENCH PLUG TIGHT WITH PIPE DOPE
 ON THREADS AND TESTED LEAK FREE.

APPROXIMATE SHIPPING WEIGHT
 2,020 LBS.
 TANK VENT CAPACITY
 126,000 PRIMARY TANK
 126,000 SECONDARY TANK

DRW BY
 REV No
 1



AceSkidLite II - 1,000 GALLON

ACE PART No. **AC01000U2K4** QTY: 1

(F:111ACSHOPISKIDU2K4101000U2ORTHO.GCD-1:32)

SECONDARY TANK
 SHELL: 10 GAUGE (9/64")
 HEAD: 10 GAUGE (9/64")

INTERIOR:
 BARE STEEL

JOB ID No. - ACE HOUSE PAPER No. - ENG. FILE No. -

09-01-01 SUPERCEDES 10-1-00

SHEET
 2
 OF

NOTE:
1. ALL NOMINAL DIMENSIONS ARE 2"±

BILL OF MATERIAL

ITEM	QTY	NAME	DESCRIPTION	MATL	PART No.	NOTES
1	2	SKID ANGLE	L3 X 3 X 1/4 X 101" LONG	A36	-	MOUNT, COAT
2	2	SKID STIFFENER	1 1/4" SCH. 40 PIPE X 49" LONG	-	-	MOUNT, COAT
3	-	SKID CAP	PLATE	A36	-	SEE DTL SHT

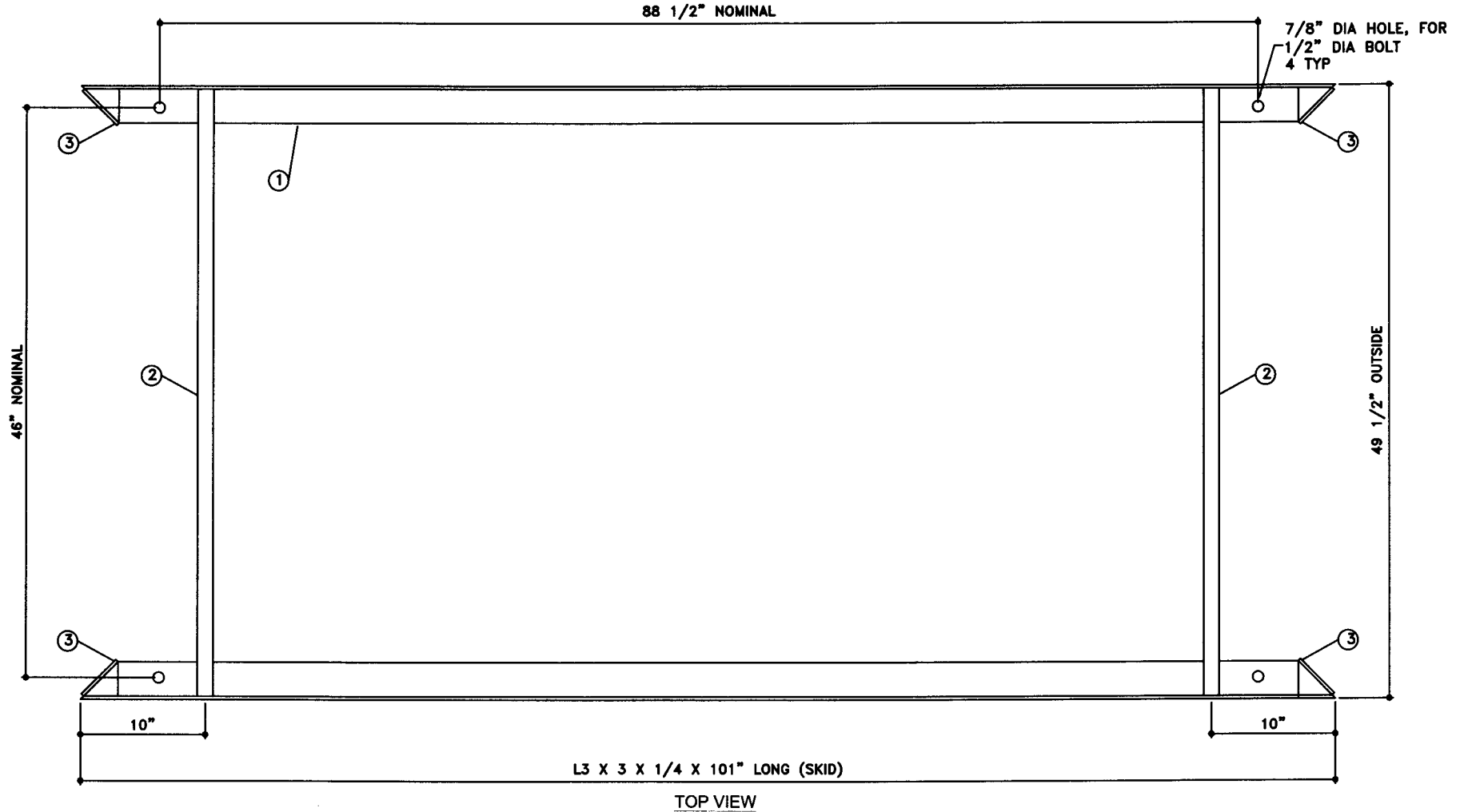

JOB ID No.	TOLERANCES
-	SKID
ACE HOUSE PAPER No.	OVERALL LENGTH -1/4" / +1/4"
ENG. FILE No.	OVERALL WIDTH -1/4" / +1/4"
-	OVERALL HEIGHT -1/4" / +1/4"
-	OTHER DIMENSIONS -1/8" / +1/8"

QUANTITY	PART NAME
1	SKID - DETAILS
-	-
-	-
-	-
-	-
-	-
(1:08)	ACE PART No. AC01000U2K4

No.	DRAWING / REVISION	DRAWN BY	CHECKED BY	SHEET
1	1ST SUBMITTAL	-	-	OF
-	-	-	-	-
-	-	-	-	-
-	-	-	-	-
-	-	-	-	-
01-01-01 SUPERCEDES				